

**'SMART' CANE FOR THE VISUALLY IMPAIRED:  
TECHNOLOGICAL SOLUTIONS FOR DETECTING  
KNEE-ABOVE OBSTACLES AND ACCESSING PUBLIC BUSES**

**Paul Rohan<sup>1</sup>, Garg Ankush<sup>1</sup>, Singh Vaibhav<sup>1</sup>, Mehra Dheeraj<sup>1</sup>,  
Balakrishnan M.<sup>1</sup>, Paul Kolin<sup>1</sup>, Manocha Dipendra<sup>2</sup>**

<sup>1</sup>Department of Computer Science and Engineering  
Indian Institute of Technology, Delhi  
Block II-A, Hauz Khas  
New Delhi -110 016  
India  
Phone: (91) (11) 2659-6033  
Fax: (91) (11) 2658-1060  
Email: kolin@cse.iitd.ernet.in

and

<sup>2</sup>National Association for the Blind, NAB  
Sector V, RK Puram, New Delhi-110 022  
India  
Phone: (91) (11) 26102944  
Fax: (91) (11) 26187650  
Email: dipendra.manocha@gmail.com

## SUMMARY

### Purpose

Visually challenged persons face constraints in independent mobility and navigation. White cane can only be used to detect obstacles up to knee-level within a range of only 2-3 feet. Further, the visually challenged are unable to access the bus transport system without sighted assistance as they cannot read the route number and are unsure about the physical location of the bus and its entry/exit door. This project is aimed at developing two systems to address these problems: (i) Cane mounted knee-above obstacle detection and warning system using ultrasound beam to enhance the horizontal and vertical detection range, and (ii) User-triggered bus identification and homing system using radio-frequency (RF) communication.

### Results

#### *Cane Mounted Knee-Above Obstacle Detection and Warning System*

A detachable unit comprising of an ultrasonic ranger, vibrator and a microcontroller was developed which offers an increased range of 3m and can detect obstacles above knee level. Distance information is conveyed to the user through a vibrator. Vibration frequency increases as the obstacle comes closer. There are two modes of operation: (i) *Less than 1m range*: useful while navigating within a room; and (ii) *Greater than 1m range*: used while navigating outdoors. In trials conducted at the National Association for the Blind, Delhi, users were able to detect obstacles like horizontal bars, open windows and platforms raised above the ground (tables, sides of trucks, etc.) which would remain undetected with the traditional cane. Thus, users become aware of obstacles much before detecting them by physical contact with the cane or body.

#### *User-Triggered Bus Identification and Homing System*

This device consists of two modules: (i) *User Module*, carried by the user, (ii) *Bus Module*, placed at the entry of each bus. Once the user hears a bus approaching the bus stop, he presses the Query Button on the User Module which transmits an RF signal to all the buses in the vicinity. Each bus module responds by transmitting its route number. All numbers received are sequentially spoken out by the user module. The user selects the bus number of interest by pressing the Select Button after that number is read out. This triggers voice output of the bus number from the entry of the selected bus that acts as an auditory cue and assists the person in moving towards the gate of the bus. This system is generic and can be used for trams, trains etc. where multiple route vehicles are being boarded from the same location. The same hardware can be adapted for locating public facilities like stairs, lifts, washrooms etc. in buildings.

### Conclusions

We have devised two systems to improve independent mobility and access to public transport system. For both the systems, the projected cost of user modules is under 50 USD each making them suitable for developing country needs. These systems reduce dependence on sighted assistance and thereby empower the visually challenged.

**Key Words:** Visually impaired; obstacle-detection; bus number identification

## **PURPOSE OF THE STUDY**

Among the many challenges faced by the visually challenged persons are the constraints of independent mobility. These stem from hazards while walking in an unfamiliar environment and accessing the public transport system. We have attempted to address these two day-to-day problems in this project by harnessing recent advancements in embedded system technologies.

### **1. Personal mobility**

The white cane is the most popular navigation tool used by the visually challenged. It enables them to effectively scan the area in front and detect obstacles on the ground such as uneven surfaces, holes, steps, walls etc. Its low cost, portability and ease of operation make it an extremely popular navigation aid.

But the cane has two major shortcomings: (i) In a practical setting, it can only be used to detect obstacles up to knee-level. Hence, potentially hazardous obstacles like protruding window panes, raised platforms and horizontal bars go undetected. (ii) The detection range of the cane is restricted to 1-2 feet from the user. Certain obstacles (e.g. a moving vehicle) cannot be detected till they are dangerously close to the person.

A few obstacle detection systems are available in the international market but none of them come at a price that is affordable for people in developing countries. It is no coincidence that a majority of visually handicapped are also poor. To cite some examples, the K-Sonar [K-Sonar, 2006] is priced at 1069 USD and the Ultracane [Hoyle et al, 2006] costs 770 USD. Another mobility cane for the blind, [Elchinger, 1981] employs auditory output for conveying distance information. It is difficult to use because voice output masks other important auditory cues necessary for safety and orientation, e.g., sound emanating from an approaching vehicle.

*Thus, there is a need for a knee-above obstacle detection and warning system that provides distance information through a non-interfering stimulus and also comes at an affordable price.*

### **2. Accessing the public transport system**

For nearly all of the 40 million blind people and 124 million visually impaired people worldwide, public transport is the only viable mobility option. Nearly 80% of the blind and visually impaired live in the developing world where any other transport option is not foreseen in the near future.

Accessing the public transport system is difficult for the visually challenged as it is seldom tuned to their special needs of orientation guidance and timely route information through a perceptible medium. Ability to use the transport system is a basic requirement in today's civilization as it empowers the person to seek education, work and social connectivity.

In the bus transport system, each bus is assigned a route number that determines its route through the city. This number is generally displayed on the front top panel of the bus. Thus, a visually challenged person has to rely on a fellow traveler to get timely route information. The situation gets difficult during non-office hours and at less-frequently used bus stops where the person might be alone. Also, the user would like to know about all the buses that arrive at the bus stop so as to make a choice between them. It is commonly observed that a number of buses arrive together and line up arbitrarily at the bus stop. Thus even after identification the user cannot navigate towards the bus since he is unsure about its physical location.

The arrival time of the bus at a particular bus stop is variable and may deviate considerably from the scheduled arrival time listed in the time table. Hence a system at the bus stop that announces the expected arrival time of a bus is rendered ineffective. A majority of the bus stops in the developing world consist of a single shed, with no or unreliable power supply. Hence placing a device at the bus stop is not feasible.

*Hence, there is a need for a user 'owned' and enabled system to obtain the route number of buses approaching a bus stop. The system must also provide repetitive auditory cues, enabling the user to navigate towards the entry of the bus.*

### **3. Aims of the project**

The twin aims of the project were to develop:

1. A cane-mounted detachable unit that increases the detection range of the white cane and detects obstacles above knee level.
2. A user-triggered bus identification and homing system that informs the route number of buses arriving at a bus stop and provides an auditory cue to facilitate boarding.

## **MATERIALS AND METHODS**

### **1. Cane mounted knee-above obstacle detection and warning system**

We developed a detachable unit that can be placed on one fold of the white cane. The device employs directional, ultrasound based receiver-transmitter technology to detect obstacles above knee height. The user obtains distance information through vibratory patterns that vary with changing obstacle distance (figure 1). As the obstacle comes closer the vibration frequency increases incrementally.

While walking, the user keeps the cane at a convenient inclination. As a result the ultrasonic detection cone is directed upwards and allows detection of knee-above obstacles. Preliminary data collected from users at the National Association for the Blind (NAB), Delhi indicates that on an average the cane makes an acute angle of 55 degrees with the ground. While walking, this angle varies between 50 to 60 degrees. Since this deviation is small, the detection zone is mostly stable.

The core of the device consists of an 8051 microcontroller [ATMEL, 2005] and SRF04 ultrasonic ranger [Devantech, 2003]. Vibrations are produced using a cell phone

vibrator. Its low cost and easy availability make it suitable for our application. The following are the main features of the device.

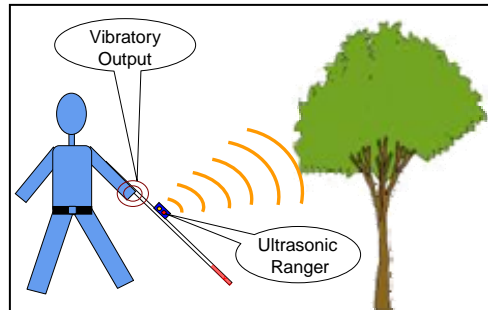

**Figure 1: Concept: Ultrasound based ranging combined with vibratory output**

*1.1 User controlled detection range*

The system has two modes of operation which are selectable through the mode select button on the device.

- Short Range Mode (< 1.00 m): Useful while navigating within a room
- Long Range Mode (> 1.00 m): Used outdoors e.g. roads, parks etc.

The detection range is divided into four sub-ranges for the Long Range Mode and three for the Short Range Mode. Each sub-range is associated with a unique vibratory pattern. Thus by recognizing the vibratory pattern the user can infer the obstacle distance (see table1, figures 2 and 3). e.g., If the unit is vibrating in pattern 3 in the long range mode, the user can infer that the obstacle distance is 1-2 m.

**Table 1: Division of Detection Range into sub-ranges and corresponding Vibratory Patterns**

Detection Zone	Vibratory Pattern	Obstacle distance (cm)	
		Long Range Mode	Short Range Mode
I	1	3-50	3-30
II	2	50-100	30-60
III	3	100-200	60-100
IV	4	200-300	-

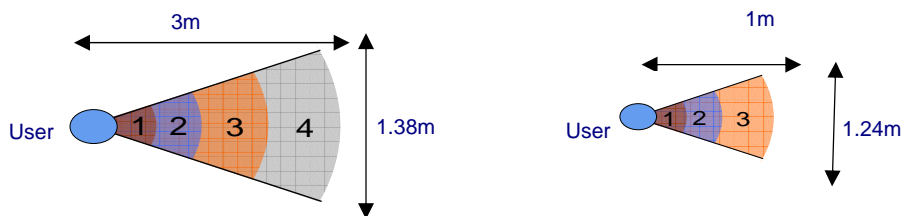

**Figure 2: Top view showing the horizontal and angular coverage of the detection zone (colored) for Long Range Mode (left) and Short Range Mode (right).**

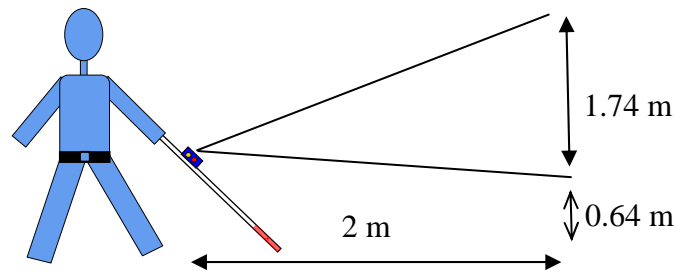

**Figure 3: Side view illustrating the horizontal and vertical coverage of the detection zone at a distance of 2m from the user.**

### *1.2 Rechargeable batteries*

The module runs on a standard Li-ion rechargeable battery. For charging the user connects an AC or USB adapter (similar to charging a cell phone). Different beep tones, produced from a buzzer, indicate conditions like low battery power, charging in progress and over-temperature conditions. At many public places like airports, shopping malls etc. there are charging zones which have charger leads for charging cell phones. In the long run, we visualize that there would be an additional charger lead for charging this device.

### *1.3 Detachable unit*

The unit can be detached from the cane and used as a general purpose distance estimation device. An attachment mechanism was developed so that the user can attach the device to the cane without sighted assistance.

### *1.4 User Controls*

The power and mode select buttons are easily locatable and possess Braille markings for easy identification. In addition, since people have different skin sensitivities there is a knob to adjust the intensity of vibrations.

## **2. User-triggered bus identification and homing system**

The system consists of two modules: (i) *User Module*: A handheld device carried by the user and, (ii) *Bus Module*: A module placed at the entry of each bus (This module can be adapted for other modes of public transport). There are two stages of operation:

(i) Query stage and (ii) Selection and Tracking stage.

### *2.1 Query Stage*

Once the user hears a bus approaching the bus stop, he presses the **Query Button** in the User Module. A query signal is transmitted to all buses in vicinity using a radio frequency (RF) transmitter which activates the Bus module placed in each bus. It responds by transmitting the 3-digit route number which is stored in the module.

All the bus numbers received by the user module are spoken out to the user through a small speaker in the handheld unit (figure 4). As an example, assume that buses 501 and 620 are at a bus stop. Once the user queries, he will hear the following:

| five | zero | one | **(gap)** six | two | zero | **(gap)** (Where ‘|’ indicates that the numbers are being read out one by one.)

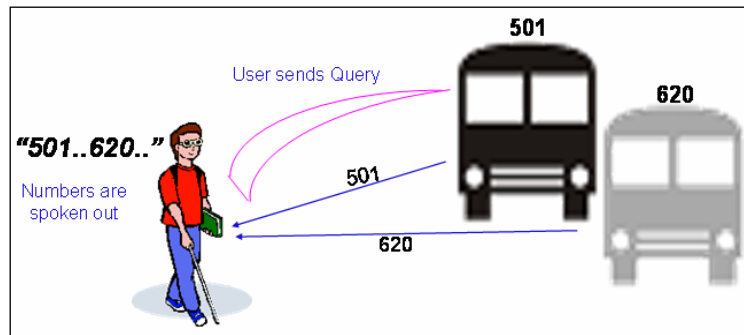

**Figure 4: User queries all buses for route number. Numbers received are spoken out to the user**

### 2.2 Selection and Tracking Stage

If the user is interested in boarding the bus whose number is being read out, he presses the **Select Button**, in the interval after that number has been read out. e.g., If the user wants to board bus number 501, he presses the button after (| five | zero | one |) has been read out. **Sample:** | five | zero | one | **(button pressed)** | six | two | zero | **(gap)**

The user module now transmits the selected number to all the buses. Each bus module compares the received number with the number stored in the module itself. If the number matches, i.e. the user is interested in that particular bus, then there is a voice output of the number from the entry of the selected bus. This acts as an auditory cue, and assists the visually challenged person to move towards the entry of the bus. Other buses that haven't been selected, do not respond (figure 5).

Once the user selects a particular bus, a small bulb would start flickering in the driver's control panel (like a car indicator). This gives an indication to the driver that a person with special needs is interested in boarding the bus. Hence, the driver can wait for a slightly longer duration to allow the user to board the bus safely. The bulb stops flickering automatically after a fixed time period.

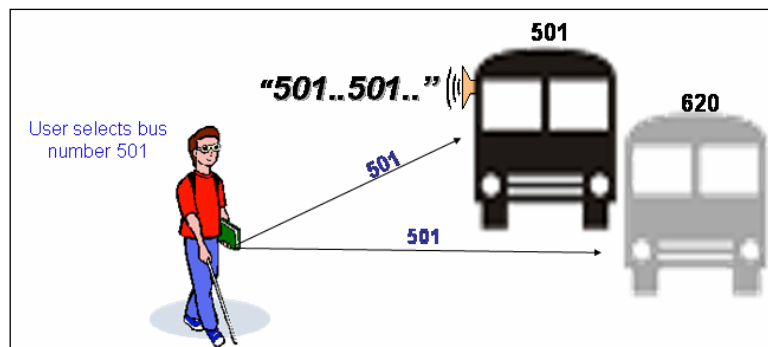
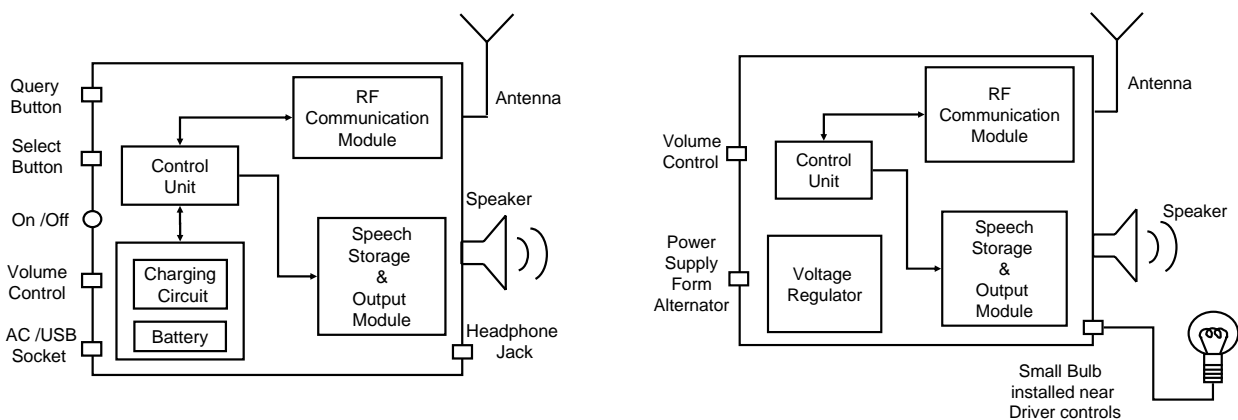

**Figure 5: User selects the bus of interest to trigger an auditory cue from its entry**

Generally, the arrival of a bus is followed by ‘chaotic’ movement of people towards the entry. After moving a short distance, the user might require the cue again. In such a case, the user can press the selection button again to activate speaking of the route number from the bus.

### 2.3 Functional Description

The system employs CC1010 RF-transceivers [CC1010, 2006] for wireless data transmission. Non-directionality and a medium range of RF transmissions (40-50m) make it suitable for our application. While operating the device, the user does not have to worry, whether the bus is standing towards his left, right, back or in front. Both the user and the bus modules are fitted with an antenna for wireless communication, which can be folded when the device is not in use.



**Figure 6: Top Level Block Diagram for User Module (left) and Bus Module (right)**

Voice output is produced using stored speech samples, making the device language independent. One can record in any language without a fundamental change in the design. The user might desire, that the numbers being read out should be inaudible to fellow travelers. For this purpose the unit is fitted with a headphone jack, where the user can insert a mono headphone to hear bus numbers. The user module runs on rechargeable Li-ion batteries (similar to the cane module in the previous system). The bus module derives power from the main engine battery (figure 6).

## RESULTS

### 1. Cane mounted knee-above obstacle detection and warning system

The team developed a prototype of the system and conducted trials with volunteers from NAB.

#### 1.1 Detection of knee-above obstacles

Experimentation was conducted in an unfamiliar environment possessing knee-above obstacles like a raised railing, side of a truck and the edge of a table. Volunteers did not



have any prior knowledge about the identity or location of these obstacles. After initial familiarization with the vibratory patterns, users were instructed to walk till they detected the presence of an obstacle in their path. Two sets of observations were taken: first, with the system mounted on the cane and then only with the white cane. The starting position of the subject was changed before the second set of observations.

Figure 7(a) illustrates that the user was able to detect the raised side of a stationary truck from a distance of 3m. Without the unit, the obstacle could not be detected until the user collided with it. Figure 7(b) shows that the major portion of the cane went underneath the side of the truck and hence failed to warn the user.



(a)



(b)

**Figure 7: Detection of raised side of a truck**

**(a) With the unit mounted on the cane the user detects the obstacle 3m away.**

**(b) Without the unit the user collides with the obstacle**

Figure 8(a) shows a similar result where the user could detect a horizontal bar (7cm thick, raised 1m from the ground) from a distance of 2.5m. Without the unit, the bar was detected only when the upper portion of the cane came in contact with it (figure 8(b)).



(a)



(b)

**Figure 8: Detection of raised horizontal bar. (a) With the unit the user detects a bar 2.5m away and (b) collides with it without the unit**

### *1.2 Negotiating common obstacles*

The user can also detect obstacles like walls, people and tables much before coming in contact with them. This information can be used to negotiate obstacles. Figure 9(a)

shows a path finding experiment where the user is able to find a clear path without coming in contact with arbitrarily positioned observers.

### 1.3 Other Characteristics

The unit can detect an object of thickness 3cm (minimum) at a distance of 3m. Since an ultrasound beam is used for ranging, obstacles like a glass or a liquid surface can also be detected. A fully charged battery lasts about 10 hours of constant usage before recharging.



(a)



(b)

**Figure 9: (a) Path finding experiment, (b) User attaching the device to the cane**

## 2. User-triggered bus identification and homing system

A concept demonstrator of the system was developed and user feedback was taken on its operation. The User module takes a maximum time of 4sec to obtain and read out the bus numbers (assuming that a maximum of five buses would be at a bus stop at a particular instant of time). In most cases there would only be one or two buses and hence the operation would finish in about 2 sec.

An experiment was carried out at two bus stops in Delhi, to determine the duration between the time instant when the user hears a bus approaching a bus stop and the time when the bus leaves the bus stop. This is the time period available to accomplish the query and the select stages. The average stoppage time was found to be about 10 sec, which gives ample time to complete the operation of the system.

## DISCUSSION

Navigation for the visually impaired is often described as walking in a minefield where the person discovers obstacles only by unexpectedly coming in contact with them. The knee-above obstacle detection and warning system increases the detection range of the white cane and warns the user of knee above obstacles much before colliding with them. It gives a much wider feel of the surroundings, improves safety and hence gives confidence to the user.

The user-triggered bus identification and homing system is controlled by the user, without any assistance from the driver or others. It gives independence to the user and

boosts self-esteem. The system described for the bus transport system is generic and can be used for trams, trains, metro rail etc. where multiple route vehicles are boarded from the same location. It can also be adapted for a building navigation system for the visually challenged wherein identification modules can be placed at important landmarks like fire-exits, staircases etc. that transmit auditory cues once selected by the user.

These systems were developed in close association with potential users. Feedback was taken during the problem formulation, concept design and prototype evaluation stages which was critical for achieving our objectives. These applications may also benefit the senior citizens.

For both the systems, the projected cost of user modules is under 50 USD each. This would place them within affordable range for users in developing countries. The cost would decline substantially once these devices are mass produced.

## **CONCLUSION**

We have devised two systems for the visually impaired, namely, an ultrasound-based cane mounted knee-above obstacle detection and warning system, and an RF based user-triggered bus identification and homing system. Initial experiments with the target group demonstrated their utility in real life scenarios. These potentially affordable systems reduce dependence on sighted assistance thereby empowering the visually challenged.

## **REFERENCES**

- Atmel Corporation, 2005, 8051 Architecture, [Internet]  
Available from: <http://www.atmel.com/products/8051/>, August 2005
- Bay Advanced Technologies Website, 2006, The BAT K-Sonar, [Internet]  
Available from: [www.batforblind.co.nz](http://www.batforblind.co.nz), June 2006
- Devantech. 2003, SRF04 Ultrasonic Ranger, [Internet].  
Available from: <http://www.acroname.com/robotics/parts/R93-SRF04.html>, August 2005
- Elchinger Gilbert M., 1981, US Patent Number 4,280,204
- Hoyle B, Withington D, Waters D. 2006, UltraCane, [Internet].  
Available from: <http://www.soundforesight.co.uk/index.html>, June 2006
- Texas Instruments Website, 2006, CC1010, [Internet]  
Available from: [http://www.chipcon.com/index.cfm?kat\\_id=2&subkat\\_id=12&dok\\_id=55](http://www.chipcon.com/index.cfm?kat_id=2&subkat_id=12&dok_id=55),  
December 2006